

PQ "Bas du Grandsonnet"  
1422 Grandson

Enquête

Plan N°	16053-015b	
Liste N°		
Echelle	1:50	
Dessiné	02.03.2020	SK
Contrôlé	02.03.2020	KV
Format	63 x 30 cm	

RC 401-B-P  
REAMENAGEMENT  
CARREFOUR RUE BASSE

Profils types



**PERRET-GENTIL**  
Ingénieurs civils - www.ingenieurs.ch

Avenue des Découvertes 12 - CP 1118  
1401 Yverdon-les-Bains

Chemin de Pré-Fleuri 6  
1006 Lausanne

+41 24 425 11 12

perret-gentil@ingenieurs.ch

Indice	Date	Dessiné	Contrôlé	Modifications
a	18.12.2020	SK	KV	Mise à jour profils et ajout détails bordures
b	19.10.2021	EM	KV	Revêtement phonoabsorbant
c				
d				
e				
f				
g				
h				
i				
j				
k				
l				

Plan dressé pour enquête









L'ingénieur :

Approuvé par la Municipalité dans sa séance du :

Le syndic :

Le secrétaire :

Légende :

-  Eléments existants
-  Eléments projetés
-  Eléments démolis
-  Eaux mixtes
-  Eaux claires
-  Réseau eau potable
-  Réseau gaz
-  Réseau Swisscom

PROFIL A - A 1:50

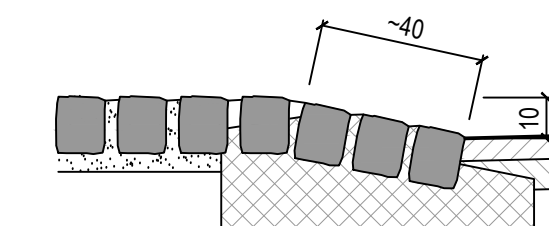
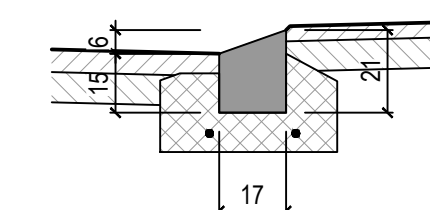
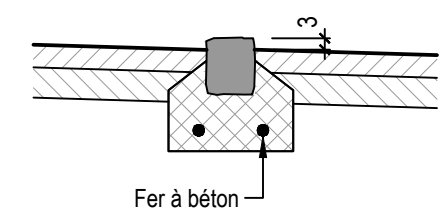
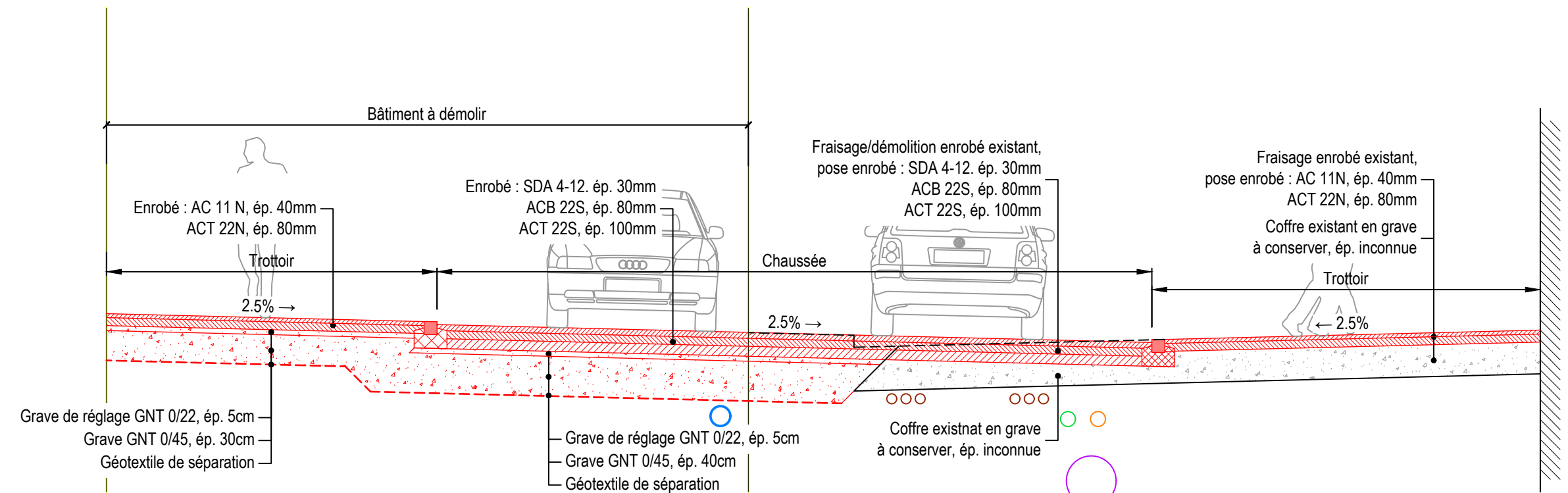

PROFIL B - B 1:50

